



TANGSLIT SELFGRIP

**Nuove Frese per Scanalatura
con Connessione Filettata
MULTI-MASTER e FLEXFIT**

TANGSLIT SELF-GRIP

Caratteristiche

ISCAR ha ampliato la linea per scanalatura introducendo le nuove frese con connessione filettata **MULTI-MASTER** e **FLEXFIT**

SELF-GRIP diametri 32 mm e 40 mm

MULTI-MASTER (MM)



TANG-GRIP diametro 50 mm

MULTI-MASTER (MM)

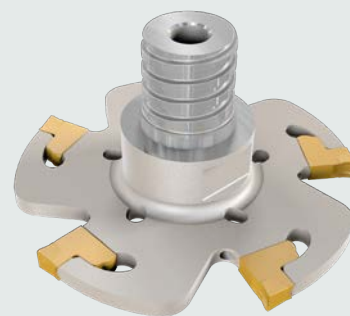









FLEXFIT (M)



FLEXFIT (M)

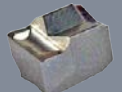

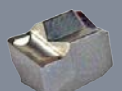
TANGSLIT SELF-GRIP

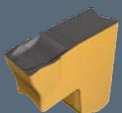
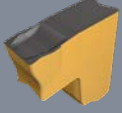
Inseriti	Dia.	Prodotti		Inseriti		Dimensione stelo	
		SELF-GRIP	TANG-SLIT			MULTI-MASTER (MM) 	FLEX-FIT (M) 
2 mm	32	Tipo di connessione MM M 		GSFN 2		T08	M08
3 mm				GSAN 3			
2 mm	40	Tipo di connessione MM M 		GSFN 2		T10	M10
3 mm				GSAN 3			
2 mm	50	Tipo di connessione MM M 		TAG 2		T12	M12
3 mm				TAG 3			

*MM=MULTI-MASTER

*M=FLEXFIT

*Per ottenere le migliori prestazioni utilizzare la refrigerazione interna con gli steli tipo "CH".

Esempio - Stelo: MM S-A-L090/14-C12-T08-CH + Fresa: SGSF 32-2-MM T08-3Z-JHP

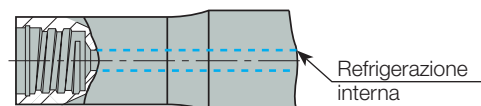

TANGSLIT SELFGRIP**Caratteristiche**

- Connessione intercambiabile - nessun setup
- Possono essere montate su qualsiasi stelo standard MULTI-MASTER e FLEXFIT
- Elevata produttività, ampio numero di denti in relazione al diametro
- Gamma diametri 32-50 mm
- Efficiente sistema di refrigerazione direzionato su ogni tagliente

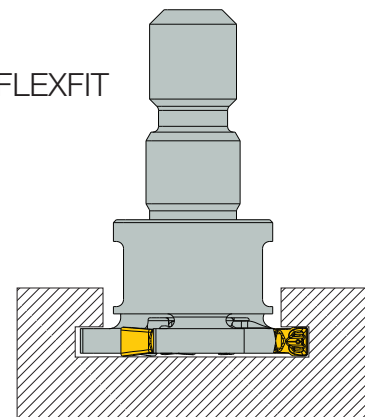

**Cliccare per
il filmato**

▶ <https://youtu.be/wYrOFIS1p7I>

Per qualsiasi ulteriore informazione potete contattare l'Ufficio Marketing o consultare il catalogo elettronico sul sito www.iscaritalia.it, dove sono sempre disponibili in tempo reale tutte le informazioni relative ai prodotti Iscar (quote, dati di taglio, prezzi, disponibilità, ...).

Cordiali saluti.

ISCAR ITALIA Srl

TANGSLIT SELFGRIP

SGSF/A-M-JHP

Frese di piccolo diametro con attacco FLEXFIT per scanalatura

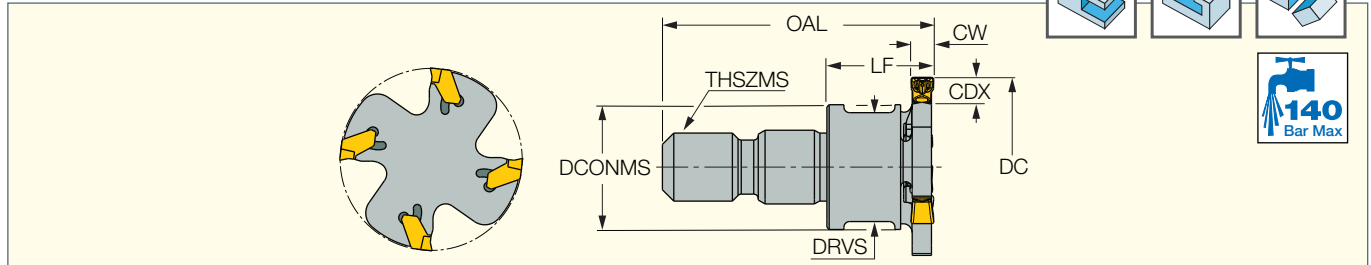

Descrizione	DC	CW	CDX	CICT ⁽¹⁾	DCONMS	THSZMS	LF	OAL	DRVS ⁽²⁾	MIID	
SGSF 32-2-M08-3Z-JHP	32.00	2.00	7.80	3	13.00	M08	12.00	29.50	9.6	GSFN 2...	ESG 1.4-2*
SGSA 32-3-M08-4Z-JHP	32.00	3.00	7.80	4	13.00	M08	12.00	29.50	9.6	GSAN 3...	ESG 1.4-2*
SGSF 40-2-M10-4Z-JHP	40.00	2.00	11.80	4	18.00	M10	12.00	29.50	15.0	GSFN 2...	ESG 1.4-2*
SGSA 40-3-M10-6Z-JHP	40.00	3.00	11.80	6	18.00	M10	12.00	29.50	15.0	GSAN 3...	ESG 1.4-2*

⁽¹⁾ Numero di inserti ⁽²⁾ Dimensione della chiave piatta

* Opzionale, ordinare separatamente

SGSF/A-MM-JHP

Frese di piccolo diametro con attacco MULTI-MASTER per scanalatura

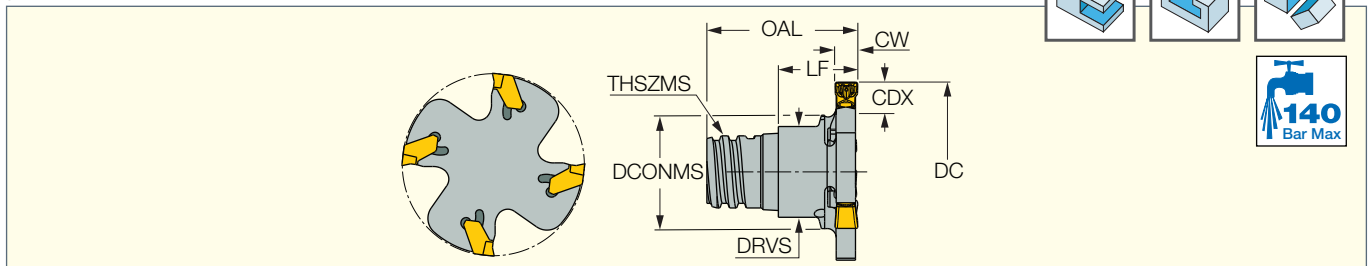

Descrizione	DC	CW	CDX	CICT ⁽¹⁾	DCONMS	THSZMS	LF	OAL	DRVS ⁽²⁾	MIID	
SGSF 32-2-MMT08-3Z-JHP	32.00	2.00	9.00	3	11.70	T08	10.60	18.10	10.0	GSFN 2...	ESG 1.4-2*
SGSA 32-3-MMT08-4Z-JHP	32.00	3.00	9.00	4	11.70	T08	11.40	18.90	10.0	GSAN 3...	ESG 1.4-2*
SGSF 40-2-MMT10-4Z-JHP	40.00	2.00	11.30	4	15.30	T10	10.60	21.90	13.0	GSFN 2...	ESG 1.4-2*
SGSA 40-3-MMT10-6Z-JHP	40.00	3.00	11.30	6	15.30	T10	11.40	22.70	13.0	GSAN 3...	ESG 1.4-2*

⁽¹⁾ Numero di inserti ⁽²⁾ Dimensione chiave piatta

* Opzionale, ordinare separatamente

TANGSLIT SELFGRIP**TGSF-M-JHP**

Frese di piccolo diametro con attacco FLEXFIT
per scanalatura

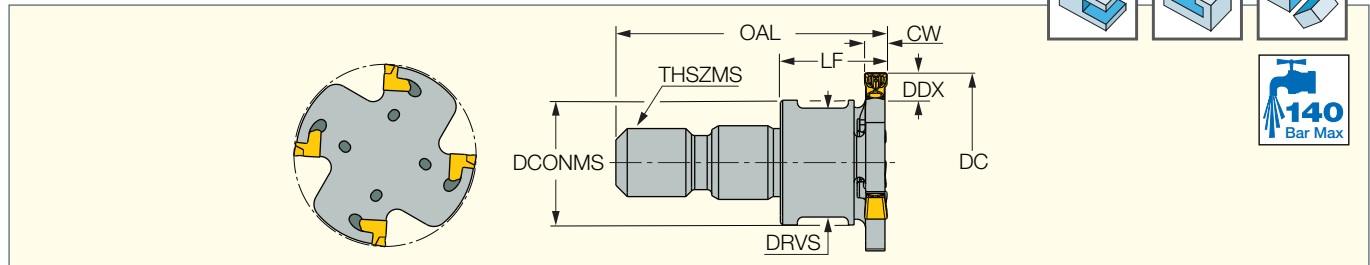

Descrizione	DC	CW	CDX	CICT ⁽¹⁾	DCONMS	THSZMS	LF	OAL	DRVS ⁽²⁾	MIID	
TGSF 50-2-M12 5Z-JHP	50.00	2.00	13.00	5	21.00	M12	10.80	24.00	17.0	TAG 2	ETG 2*
TGSF 50-3-M12 5Z-JHP	50.00	3.00	13.00	5	21.00	M12	10.70	24.70	17.0	TAG 3	ETG 3-4-SH*

⁽¹⁾ Numero di inserti ⁽²⁾ Dimensione chiave piatta

* Opzionale, ordinare separatamente

TGSF-MM-JHP

Frese di piccolo diametro con attacco MULTI-MASTER
per scanalatura

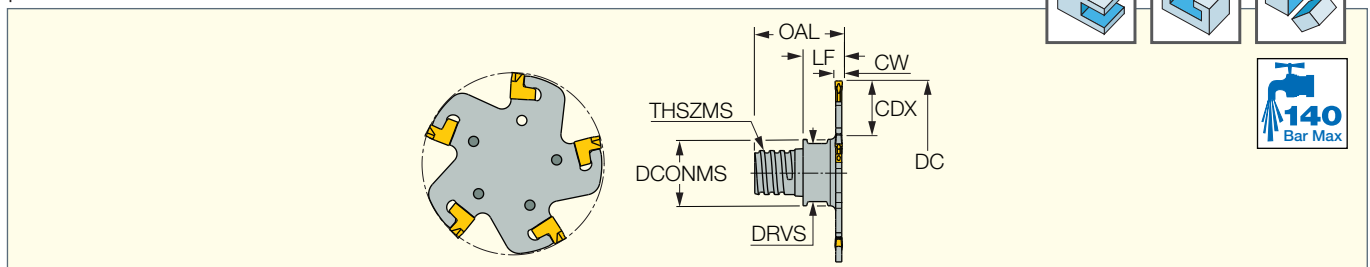

Descrizione	DC	CW	CDX	CICT ⁽¹⁾	DCONMS	THSZMS	LF	OAL	DRVS	MIID	
TGSF 50-2-MMT12-5Z-JHP	50.00	2.00	14.00	5	19.00	T12	10.70	24.00	16.0	TAG 2	ETG 2*
TGSF 50-3-MMT12-5Z-JHP	50.00	3.00	14.00	5	19.00	T12	11.50	24.70	16.0	TAG 3	ETG 3-4-SH*

⁽¹⁾ Numero di inserti ⁽²⁾ Dimensione della chiave piatta

* Opzionale, ordinare separatamente

TANGSLIT SELFGRIP**LISTINO PREZZI**

LP31-07/2019

Codice	Descrizione	Grado	SC	GrS	€uro
3345212	SGSA 32-3-M08-4Z-JHP		▲	F2	660,00
3345222	SGSA 32-3-MMT08-4Z-JHP		▲	F2	693,00
3345214	SGSA 40-3-M10-6Z-JHP		▲	F2	706,00
3345225	SGSA 40-3-MMT10-6Z-JHP		▲	F2	741,00
3345213	SGSF 40-2-M10-4Z-JHP		▲	F2	762,00
3345224	SGSF 40-2-MMT10-4Z-JHP		▲	F2	800,00
3345226	TGSF 50-2-M12 5Z-JHP		▲	F2	648,00
3345229	TGSF 50-2-MMT12-5Z-JHP		▲	F2	680,00
3345227	TGSF 50-3-M12 5Z-JHP		▲	F2	648,00
3345231	TGSF 50-3-MMT12-5Z-JHP		▲	F2	680,00

Stock: ● = Standard

▲ = Nuovo

□ = Semistandard

△ = Futura introduzione